

## Product Installation Guide

**Product Range**

**Aluminium stair nosings for stone and ceramic floor coverings**

**Product Description**

Extruded Aluminium profiles supplied with factory bonded Castellated or Smooth Textured PVC, ATI49.5 castellated aluminium or Olympic Grip slip resistant infill for screw and plug fixing.

Profiles supplied cut to customer sizes or in stock lengths for cutting on site, pre-drilled/countersunk through the tail plate for size 8 screws.

**General:**

Ensure that the steps are level and in good repair. Any remedial work should be completed in advance of fixing the stair nosings and where this requires wet treatments, these must be allowed to fully cure before commencing the installation.

**Installation:**

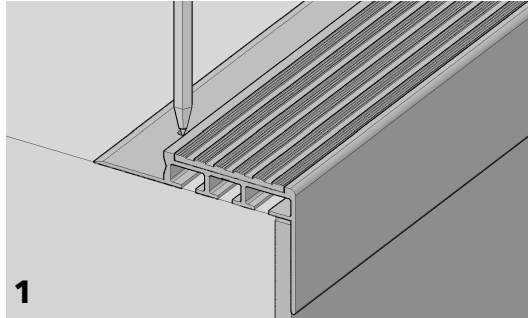

**1**

Fit the riser covering (where applicable) before placing the stair nosing profile onto the step to mark off the position of the holes.

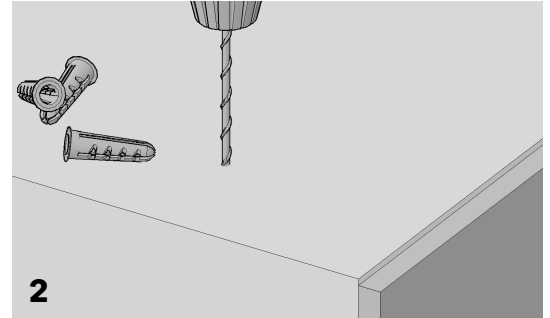

**2**

Drill according to the substrate: pilot holes in timber, holes for plastic plugs in solid surfaces.

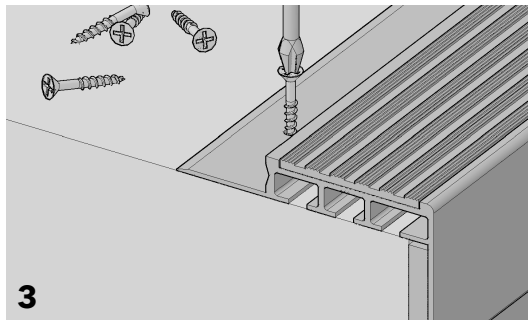

**3**

Return the stair nosing profile to the step edge, align with the drilled holes and secure with screws. Ensure that the screw heads are flush with or below the aluminium surface.

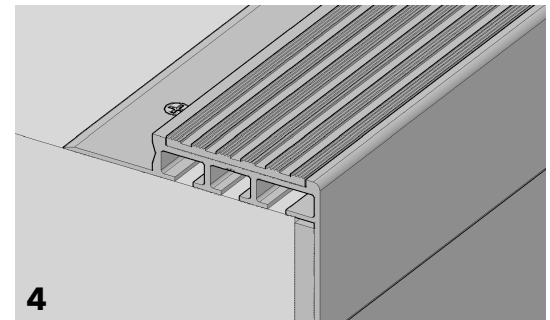

**4**

Ensure the screw heads are flush or slightly below the surface of the tail plate.

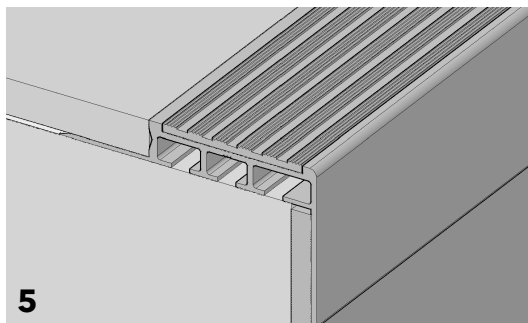

**5**

Fit the tread floor covering to finish the installation.

**Made with Precision, Finished with Care**

CAT Flooring Accessories, Units 24 A,B,C, Park Avenue Estate, Luton, Bedfordshire LU3 3BP, U.K.

T: +44 (0) 1582 561 500

email: [sales@catflooringaccessories.com](mailto:sales@catflooringaccessories.com)

website: [www.catflooringaccessories.com](http://www.catflooringaccessories.com)