

Product Installation Guide

Product Range

ALUMINIUM STAIR NOSINGS WITH FACTORY BONDED PVC INFILL FOR DRILL & PLUG FIXING

Product Description

Extruded Aluminium profiles supplied with factory bonded Castellated or Smooth Textured PVC slip resistant infill for screw and plug fixing.

Profiles supplied cut to customer sizes or in stock lengths for cutting on site, pre-drilled/countersunk through the PVC infill for size 6 or 8 screws. Check product Technical Data Sheet for more information of screw size. Matching screw head cover plugs supplied FOC.

General:

Square back nosings are to be installed to abut to floor coverings, ramped tread nosings are to be installed on top of existing floor coverings.

It is recommended that stair nosings are glued and screwed to steps to prevent 'rattle', provide the most secure fixing and ensure product performance.

Ensure that the steps are level and in good repair. Any remedial work should be completed in advance of fixing the stair nosings and where this requires wet treatments, these must be allowed to fully cure before commencing the installation.

Installation:

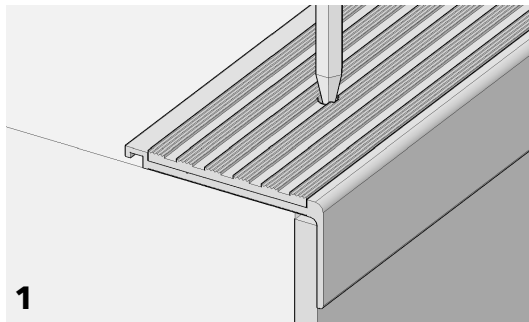

1

Fit the riser covering (where applicable) before placing the stair nosing profile onto the step to mark off the position of the holes.

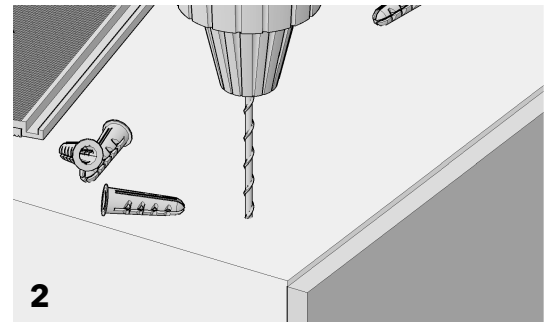

2

Drill according to the substrate: pilot holes in timber, holes for plastic plugs in solid surfaces.

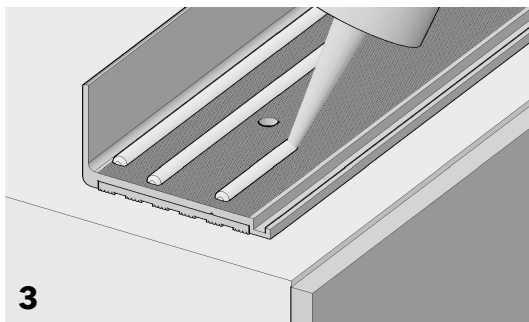

3

Ensure that the surface of the step is dust and grease free and apply two or three beads of adhesive to the underside of the stair nosing profile.

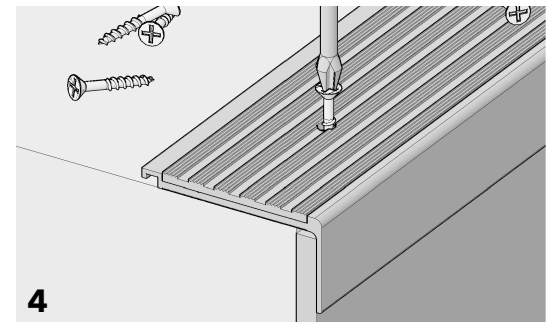

4

Return the stair nosing profile to the step edge, align with the drilled holes and secure with screws. Ensure that the screw heads are flush with or below the aluminium surface.

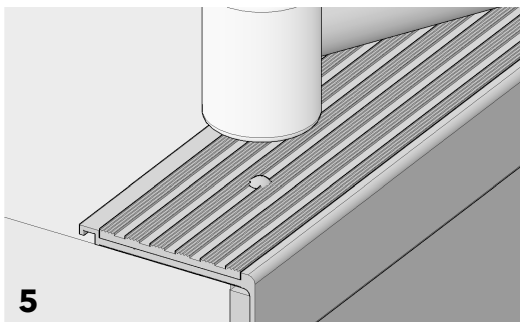

5

Apply a small 'dot' of adhesive to the screw head and insert the cover plugs. Tap firmly into place using a rubber mallet.

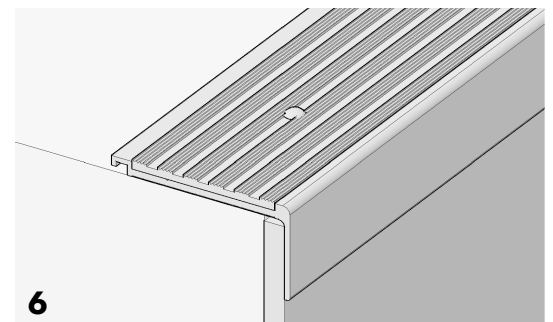

6

In the finished installation, the screw head cover plugs should be flush or slightly below the surface of the infill to ensure that they cannot be dislodged by foot traffic.

Access to the stairs should only be permitted when the adhesive has had time to fully cure.



CAT *recommends the use of STYCCO FLEX to fix any of its extensive range of stair nosings, stair edgings and stair insert products. STYCCO FLEX is a rapid curing flexible adhesive with excellent gap filling properties that can be used outside as well as inside. *subject to following the instructions given by F. Ball and Co Ltd in their STYCCO FLEX product technical data sheet, safety data sheet and installation guidelines, available in full from: www.f-ball.com

Made with Precision, Finished with Care

CAT Flooring Accessories, Units 24 A,B,C, Park Avenue Estate, Luton, Bedfordshire LU3 3BP, U.K.

T: +44 (0) 1582 561 500

email: sales@catflooringaccessories.com

website: www.catflooringaccessories.com