

## Product Installation Guide

### Product Range

### Product Description

#### Aluminium, brass, stainless steel & uPVC cap angles

Aluminium, brass, stainless steel, uPVC & brass cap profiles with a pre-punched base, suitable for mechanical and/or adhesive fixing. Suitable for timber, stone & ceramic and other hard floor coverings at the same level.

Our angles are available in various finishes. Always check the suitability of the chosen profile on our website or by contacting our sales team.

Please choose the correct profile height to suit the application:

#### Aluminium Angles

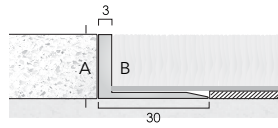

Product Code	A	B
A4.5	4.5	3
A6.5	6.5	5
A9	9	7.5
A13	13	11.5
A16	16	14.5
A19	19	17.5
A22.5	22.5	21
A25	25	23.5

#### Brass Angles

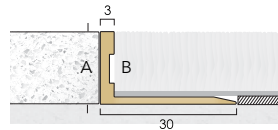

Product Code	A	B
B4.5	4.5	3.3
B6.5	6.5	5.3
B9	9	7.8
B13	13	11.8
B16	16	14.8
B19	19	17.8
B22.5	22.5	21.3
B25	25	23.8

#### Stainless Steel Angles

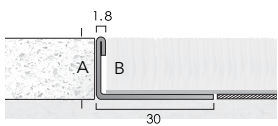

Product Code	A	B
S6.5	6.5	5.8
S9	9	8.1
S10	10	9.1
S12	12	11.1
S16	16	15.1
S19	19	18.1
S22	22	21.1
S25	25	24.1

#### Mainline A Aluminium Angles

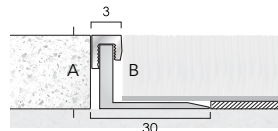

Product Code	A	B
Mainline A9	9	7.5
Mainline A11.5	11.5	10
Mainline A15.5	15.5	14
Mainline A18.5	18.5	17
Mainline A21.5	21.5	20
Mainline A25	25	23.5
Mainline A27.5	27.5	26

#### Mainline P uPVC Cap Angles

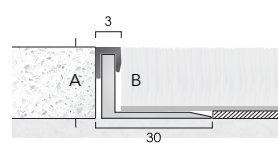

Product Code	A	B
Mainline P8.8	8.8	7.3
Mainline P11.3	11.3	9.8
Mainline P15.3	15.3	13.8
Mainline P18.3	18.3	16.8
Mainline P21.3	21.3	19.8
Mainline P24.8	24.8	23.3
Mainline P27.3	27.3	25.8

#### B6 Brass Cap Angles

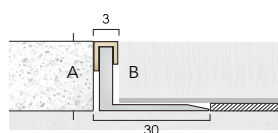

Product Code	A	B
B67.5	7.5	6
B610	10	8.5
B614	14	12.5
B617	17	15.5
B620	20	18.5
B623.5	23.5	22
B626	26	24.5

**Made with Precision, Finished with Care**

CAT Flooring Accessories, Units 24 A,B,C, Park Avenue Estate, Luton, Bedfordshire LU3 3BP, U.K.

T: +44 (0) 1582 561 500

email: [sales@catflooringaccessories.com](mailto:sales@catflooringaccessories.com)

website: [www.catflooringaccessories.com](http://www.catflooringaccessories.com)

## Product Installation Guide

### Installation

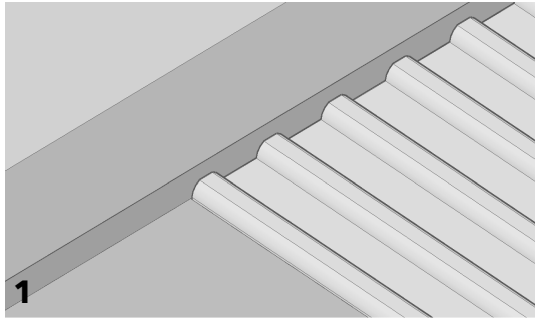

Install the flooring against which the angle will be fitted. Using a notched trowel, spread the tile adhesive evenly over the area where the angle is to be positioned. When mechanically fixing the profile to the sub-floor, mark the position of the holes and drill according to the substrate (holes to suit plugs and screws in solid substrates or pilot holes in timber).

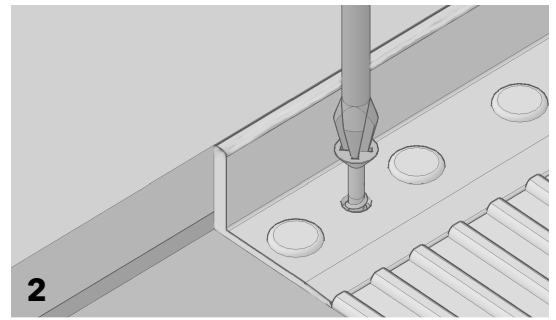

Position the angle against the flooring previously installed and bed the profile firmly into the adhesive. If mechanical fixing, secure using size 6 screws. Ensure that the screw heads are flush with or below the flooring profile's surface.

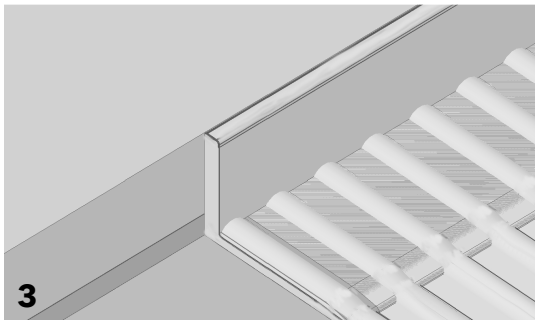

Cover the base of the installed profile with additional tile adhesive making sure that the holes in the base are completely filled.

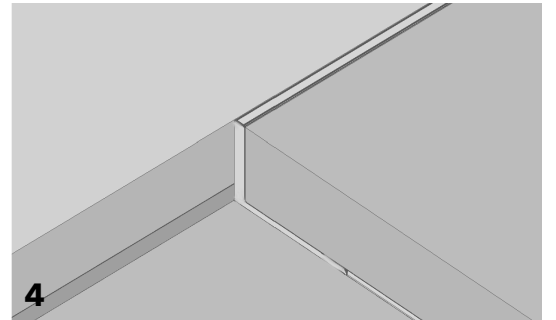

Begin laying the flooring leaving a gap for grouting between the profile and the tile.

Any grout should be removed from the surface of the profile immediately.

**Made with Precision, Finished with Care**

CAT Flooring Accessories, Units 24 A,B,C, Park Avenue Estate, Luton, Bedfordshire LU3 3BP, U.K.

T: +44 (0) 1582 561 500

email: [sales@catflooringaccessories.com](mailto:sales@catflooringaccessories.com)

website: [www.catflooringaccessories.com](http://www.catflooringaccessories.com)