

Product Installation Guide

Product Range

Glass-fibre reinforced plastic stair treads - GRPT345/55

Product Description

GRPT345/55 is a glass-fibre reinforced plastic nosing with a large 345mm tread and a 55mm riser. This economical anti-slip stair nosing is designed for internal and external use and has high slip resistance in all weather conditions.

Profiles supplied in stock lengths for cutting on site. Check product Technical Data Sheet for more information.

Important:

If any localised trimming is required, we recommend the use of a jigsaw, preferably fitted with a tungsten carbide blade or alternatively an angle grinder with a diamond tipped cutting disc.

Cutting should be carried out externally or where there is dust extraction or suitable ventilation and appropriate protective equipment should be worn. It is very important to wear PPE Safety Equipment at all times, when working with this Glass-fibre Reinforced Plastic. Recommended safety equipment includes: Eye Goggles/Spectacles, Protective Gloves, Safety Boots, P2 Type Dust Mask, Ear Defenders and Overalls.

Adhesive Only Installation on Solid Surfaces:

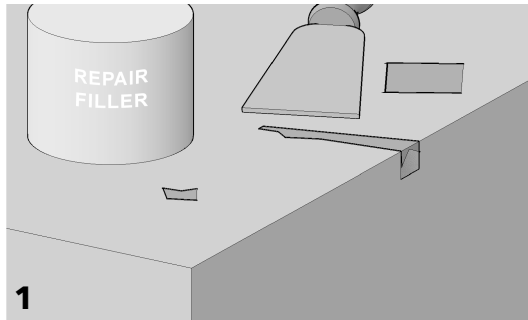

1

Ensure that the steps are level and in good repair. Any remedial work should be completed in advance of fixing the stair nosings and where this requires wet treatments, these must be allowed to fully cure before commencing the installation.

Always consider dry laying the stair treads first to ensure they fit properly and evenly.

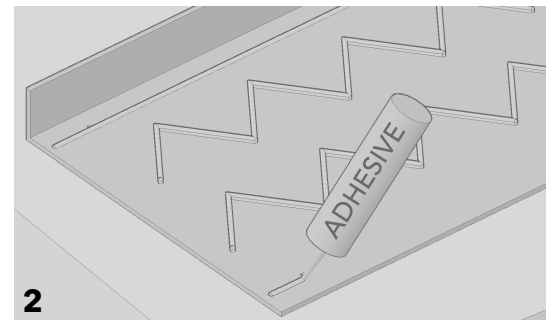

2

Ensure the step onto which the stair tread is being installed is clean, dry and free from grease.

Apply adhesive* to the underside of the GRP stair tread, running 2 beads of adhesive along the length as well as a zigzag across the centre.

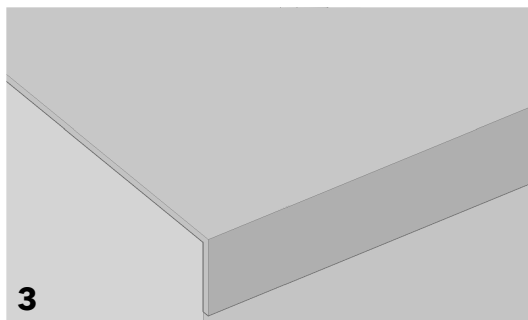

3

Carefully position the stair tread and press firmly in to place.

Pedestrian access should only be permitted when the adhesive has had time to fully cure.

CAT *recommends the use of FLEXY FIX to fix any of its extensive range of GRP stair nosings, stair tread nosings and sheet products. FLEXY FIX is a rapid curing flexible adhesive, excellent at bonding to concrete, wood, metal and steel surfaces, and can be used outside as well as inside. *subject to following the instructions given by F. Ball and Co Ltd in their FLEXY FIX product technical data sheet, safety data sheet and installation guidelines, available in full from: www.f-ball.com

Made with Precision, Finished with Care

CAT Flooring Accessories, Units 24 A,B,C, Park Avenue Estate, Luton, Bedfordshire LU3 3BP, U.K.

T: +44 (0) 1582 561 500

email: sales@catflooringaccessories.com

website: www.catflooringaccessories.com

Product Installation Guide

Mechanical Only Installation on Solid Surfaces:

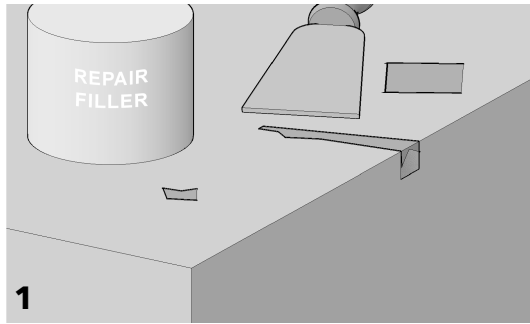

Ensure that the steps are level and in good repair. Any remedial work should be completed in advance of fixing the stair nosings and where this requires wet treatments, these must be allowed to fully cure before commencing the installation.

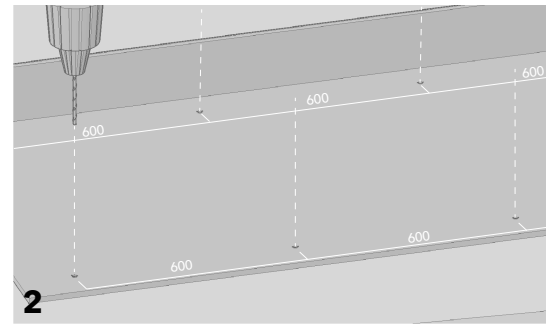

Drill holes along the length of the stair tread. The fixing points for GRP Stair Treads need to be in all 4 corners, with additional holes for fixings approximately every 600mm. Holes will need to be drilled 70mm in from the front edge and 60mm in from the back edge. If holes are to be drilled on site it is recommended to use a 4mm HSS masonry drill bit from the underside.

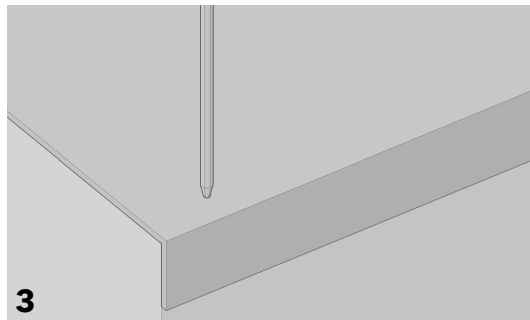

Fit the riser covering (where applicable) before placing the stair nosing profile onto the step to mark off the position of the holes.

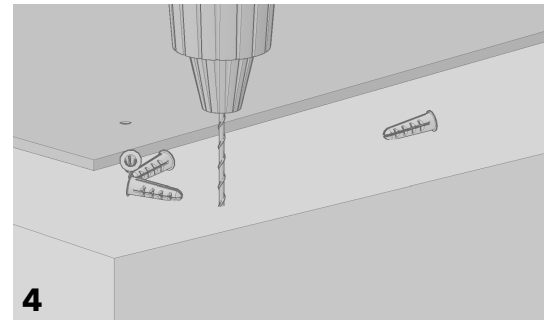

Drill according to the substrate, drill holes for plastic plugs in solid surfaces.

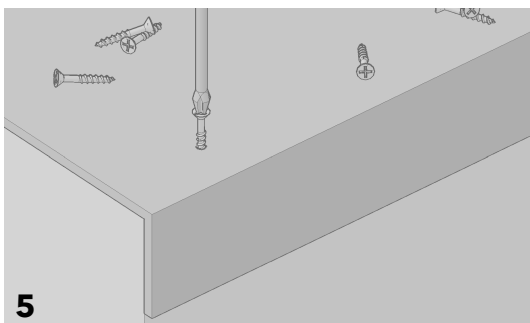

Return the stair tread profile to the step edge, align with the drilled holes and secure with screws.

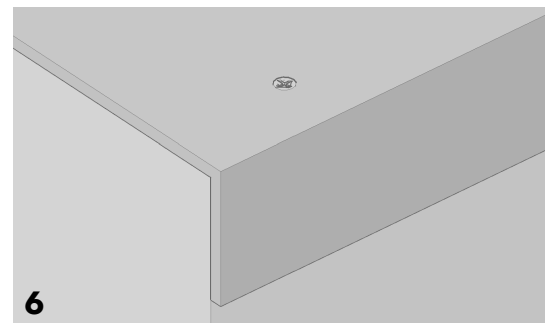

Ensure that the screw heads are flush with or below the stair tread surface.

Adhesive and Mechanical Installation on Solid Surfaces:

Generally, adhesive should be enough to secure GRP Stair Treads into position, but a double fixing method can be used if desired.

Start with Mechanical Only Installation Steps 1-4 instructions then continue with the steps below:

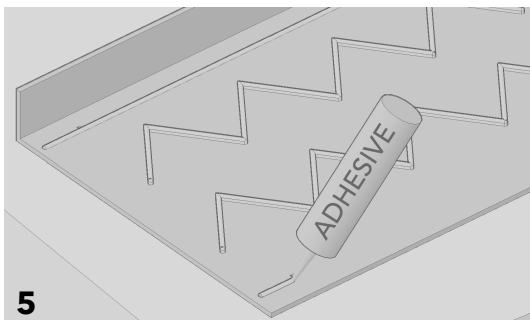

Ensure the step onto which the stair tread is being installed is clean, dry and free from grease. Apply adhesive* to the underside of the GRP stair tread, running 2-3 beads of adhesive along the length.

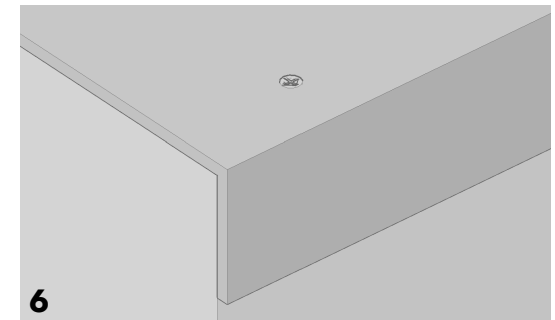

Carefully position the stair tread, making sure it's aligned with the drilled holes and press firmly in to place. Secure with screws ensuring that the screw heads are flush with or below the stair nosing tread surface.

Made with Precision, Finished with Care

Product Installation Guide

Mechanical Only Installation on Open Mesh Grating:

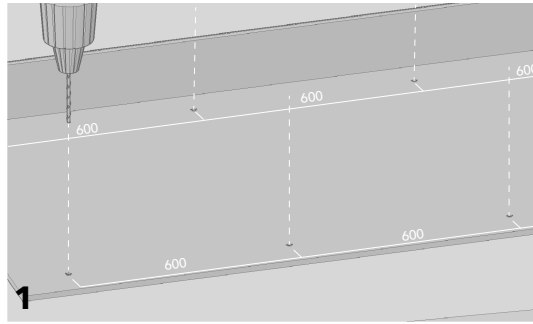

Drill holes along the length of the stair tread to align with the holes along the open mesh grating. The fixing points for GRP stair treads need to be in all 4 corners, with additional holes for fixings approximately every 600mm. Holes will need to be drilled 70mm in from the front edge and 60mm in from the back edge.

If holes are to be drilled on site it is recommended to use a 4mm HSS masonry drill bit from the underside.

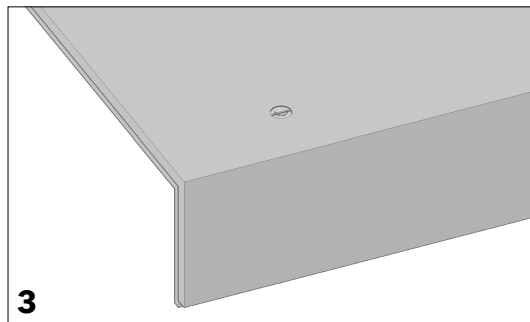

Ensure that the screw heads are tightly secured to avoid the failure of the stair tread installation.

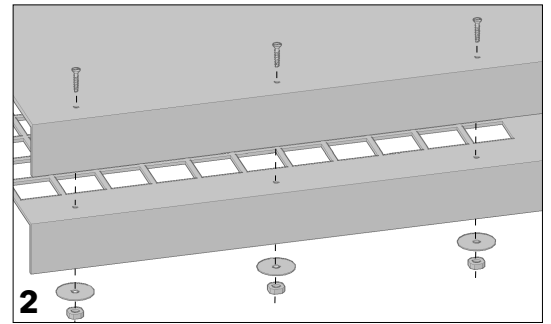

Position the stair tread onto the open mesh grating, aligning the drilled holes along the length. Secure the stair tread in place using universal saddle clip assemblies with slotted truss head bolt, nut and lock washer (all stainless steel).

Disclaimer: These methods of installation make no claim to being comprehensive but should be used as a guide. Always employ safe practices. A risk assessment and method statement should always be prepared. If in doubt please contact our Sales Office.

For instructions of how to maintain the installed GRP stair nosings, see the maintenance guide on our website.

Made with Precision, Finished with Care

CAT Flooring Accessories, Units 24 A,B,C, Park Avenue Estate, Luton, Bedfordshire LU3 3BP, U.K.

T: +44 (0) 1582 561 500

email: sales@catflooringaccessories.com

website: www.catflooringaccessories.com