

Product Installation Guide

Product Range

KLIKS® clip-in flooring profile system

Product Description

Kliks is a floor finishing system comprising of various top and base profiles which together offer a wide range of height adjustable installation combinations.

Top profiles are available in Aluminium and Brass in 2.715m lengths and Aluminium with a bonded Stainless Steel cover in 2.500m lengths. Various finishes are available in each of these materials. Please see the latest CAT Product Catalogue for details.

Base profiles are PVC and come in three sizes to provide for all floor covering thicknesses. Always select the top and base profiles that are appropriate for the application and follow this guide to ensure a satisfactory installation.

General:

Before cutting the trim, check that it is the correct profile for the intended flooring material being installed. Should assistance be required in confirming that the chosen profile is correct for the particular application or for advice on any other aspect of the installation, please contact the CAT sales office prior to commencing the installation.

Installation:

Ensure that the subfloor to which the profiles are to be fixed is in good order, dry and free from dust or any other contaminants that might compromise an effective installation.

CAT recommend that base profiles are fixed using adhesive and size 6 countersunk screws.

Check to ensure that there are no water or heating pipes close to the surface of the subfloor which might get punctured by the fixing screws.

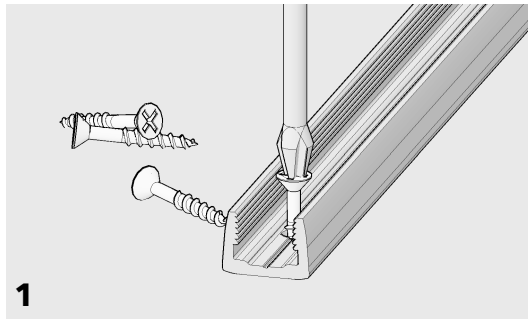

1

Base profiles are pre-drilled 50mm in from each end and then at 250mm centres. However, additional holes may be required. Use the drill holes in the base profile to mark the position of the holes to be drilled in the subfloor. Remove the profile and drill pilot holes if fixing to timber and holes to accommodate a plastic plug if fixing to solid substrate. Apply a bead of adhesive to the underside of the profile and screw firmly to the subfloor.

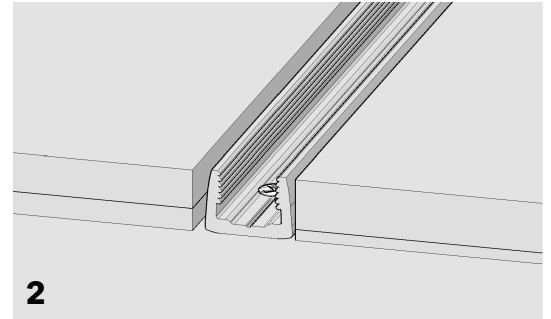

2

Fit the floor coverings either side of the base profile allowing for expansion as required.

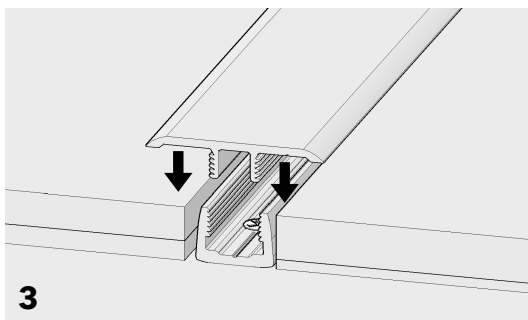

3

Starting at one end of the installed base, position the top over the base profile so that the respective Kliks features align one with the other.

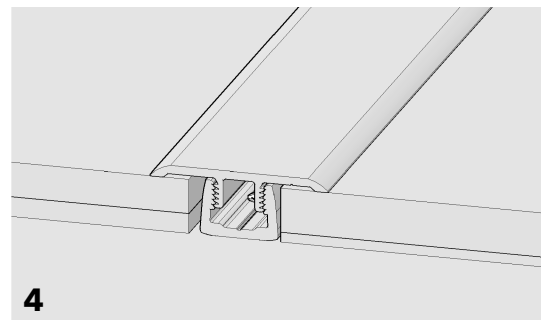

4

Connect the two profiles by firmly tapping down with a rubber mallet, continuing along the length of the piece until fully located to the level of the flooring material(s).

1. Top profiles are supplied with a protective tape applied to the surface. We recommend that this tape is left in place until the project is complete.
2. For long runs, stagger the joins in the top profile by 150mm over the joins in the base profile.
3. Whilst the interference fit of the Kliks feature is effective in every application, it is common place to apply small beads of adhesive along the inside of the base to prevent the top profile from 'creeping', particularly on long runs in heavy traffic areas.



CAT *recommends the use of STYCCO FLEX to fix any of its extensive range of stair nosings, stair edgings and stair insert products. STYCCO FLEX is a rapid curing flexible adhesive with excellent gap filling properties that can be used outside as well as inside. *subject to following the instructions given by F. Ball and Co Ltd in their STYCCO FLEX product technical data sheet, safety data sheet and installation guidelines, available in full from: www.f-ball.com

Made with Precision, Finished with Care

CAT Flooring Accessories, Units 24 A,B,C, Park Avenue Estate, Luton, Bedfordshire LU3 3BP, U.K.

T: +44 (0) 1582 561 500

email: sales@catflooringaccessories.com

website: www.catflooringaccessories.com