

Product Installation Guide

Product Range

PVC stair nosings with castellated tread & ramped back edge

Product Description

Stick-down flexible profiles suitable for light commercial and residential applications.

General:

PVC stair nosings should be fitted at room temperature, not cold environments, to avoid the possibility of contraction.

Ensure that the steps are level and in good repair. Any remedial work should be completed in advance of fixing the stair nosings and where this requires wet treatments, these must be allowed to fully cure before commencing the installation.

Installation:

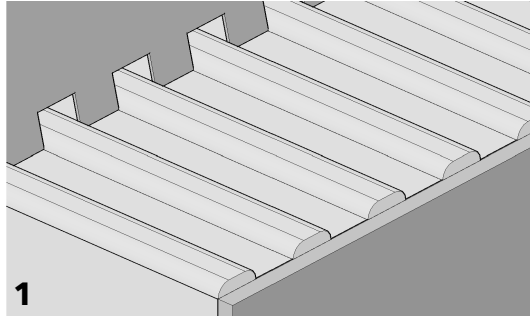

1 Apply the flooring adhesive to the step riser then cut and affix the flooring material before applying adhesive to the step tread.

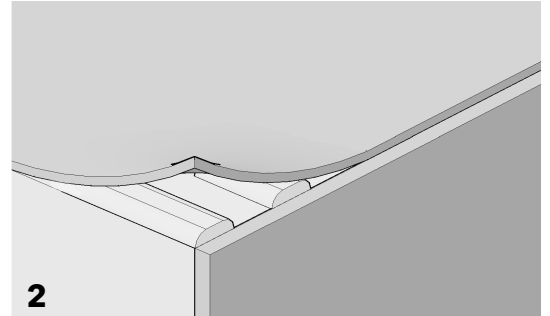

2 Cut and fit the flooring material up to the step tread edge to ensure that the stair nosing profile is fully supported when installed.

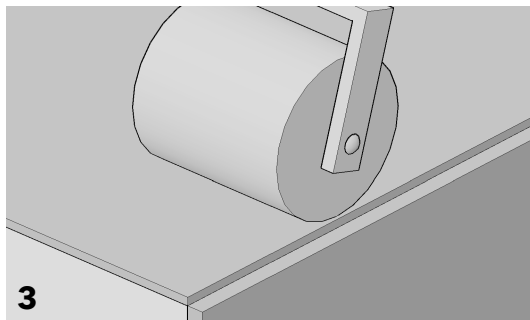

3 Ensure that the flooring material is firmly bonded to substrate surface and in particular to the nosing edge using a hand roller.

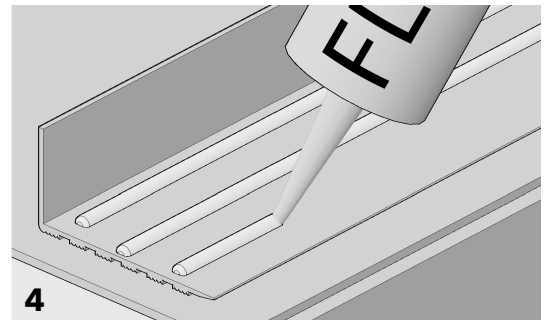

4 With flooring material securely bonded to the substrate surface, apply three beads of *adhesive to the underside of the stair nosing profile.

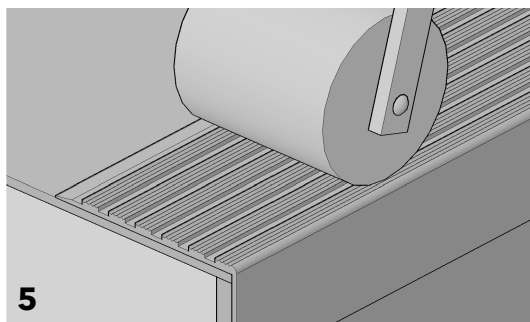

5 Carefully position the stair nosing and press firmly in to place. Use a hand roller to ensure an even spread of adhesive and achieve an even and effective bond.

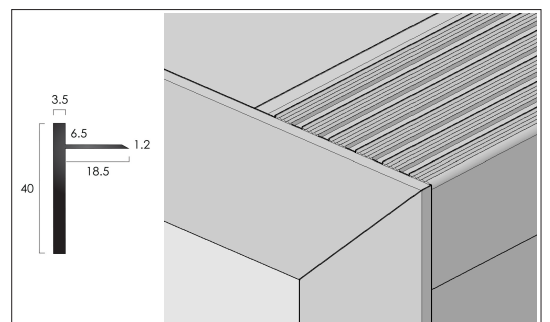

PVC Stair Nosing profiles can be installed with ST40 PVC Staircase Stringer Trim to mask the cut edge of the stair nosings.

Access to the stairs should only be permitted when the adhesive has had time to fully cure.



CAT *recommends the use of STYCCO FLEX to fix any of its extensive range of stair nosings, stair edgings and stair insert products. STYCCO FLEX is a rapid curing flexible adhesive with excellent gap filling properties that can be used outside as well as inside. *subject to following the instructions given by F. Ball and Co Ltd in their STYCCO FLEX product technical data sheet, safety data sheet and installation guidelines, available in full from: www.f-ball.com

Made with Precision, Finished with Care

CAT Flooring Accessories, Units 24 A,B,C, Park Avenue Estate, Luton, Bedfordshire LU3 3BP, U.K.

T: +44 (0) 1582 561 500

email: sales@catflooringaccessories.com

website: www.catflooringaccessories.com