

Product Installation Guide

Product Range

Ramps supplied drilled through the tail plate for concealed mechanical fixing

Product Description

We offer a range of aluminium, aluminium with bonded brass or stainless steel cover and stainless steel ramps supplied drilled through the tail plate for concealed mechanical fixing. For screw size, please see individual product Technical Data Sheets on our website.

Available in a range of high quality finishes, in various lengths and heights to suit all flooring projects. Check our current Catalogue or website to see our complete range of ramps available.

Installation:

Ensure that the subfloor to which the profiles are to be fixed is in good order, dry and free from dust or any other contaminant that might compromise an effective installation.

Check to ensure that there are no water or heating pipes close to the surface of the subfloor which might get punctured by the fixing screws.



The flooring onto which the ramp profiles are to be affixed must be in good, sound order before commencing installation.

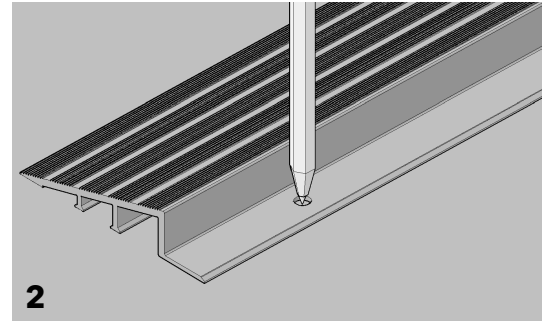

Ramps are supplied pre-drilled 50mm in from each end and then at 250mm centres. Use the drill holes to mark the positions to be drilled in the subfloor.

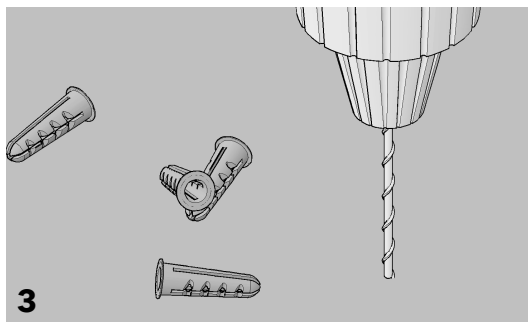

Remove the profile and drill pilot holes if fixing to timber and holes to accommodate a plastic plug if fixing to solid substrate.

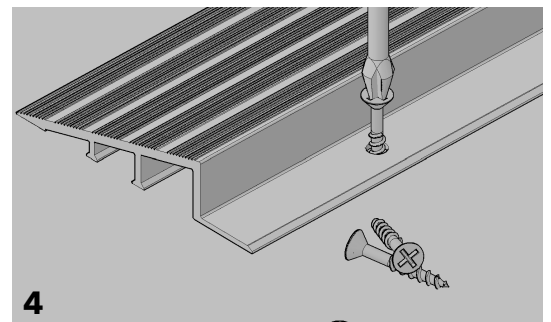

Reposition the cover plate profile over the pre-drilled holes and firmly secure with size 8 screws.

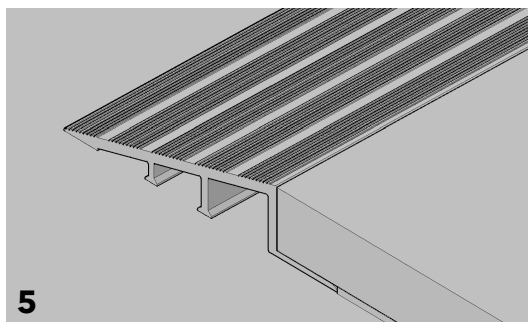

Install the floor covering over the tail plate of the ramp.

Profiles are supplied with a protective tape applied to the surface. We recommend that this tape is left in place until the project is complete.

Made with Precision, Finished with Care

CAT Flooring Accessories, Units 24 A,B,C, Park Avenue Estate, Luton, Bedfordshire LU3 3BP, U.K.

T: +44 (0) 1582 561 500

email: sales@catflooringaccessories.com

website: www.catflooringaccessories.com