

Product Installation Guide

Product Range

Staircase stringer trims - welded angles

Product Description

Welded Aluminium, Brass and uPVC angles, designed to mask the cut edge of stair nosings and floor coverings. Also suitable for use as a trim detail for landings and areas where there is no foot traffic to the leading edge, when supplied in straight lengths.

Profiles supplied in 360mm x 360mm angles in 90° or 83° options for cutting on site, undrilled for *adhesive fixing.

General:

The steps to which the staircase stringer angles are to be affixed must be in good, sound order with any remedial works being completed before commencing the installation.

It is recommended that staircase stringer angles are installed using *adhesive to achieve the most secure fixing.

Installation:

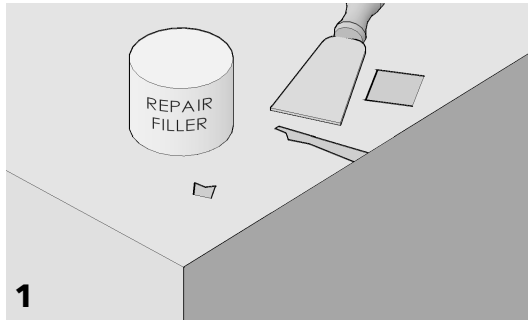

1 Ensure that the steps are level and in good repair. Any remedial work should be completed in advance of fixing the staircase stringer angles and where this requires wet treatments, these must be allowed to fully cure before commencing the installation.

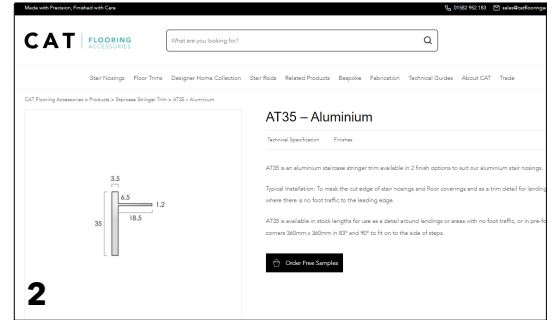

2 Prior to installing the welded angles, make sure that the correct trim has been selected for the thickness of the flooring and the gauge of the stair nosing to be installed.

If unsure, contact our sales team or view our website for more information on our stringer trims and stair nosings.

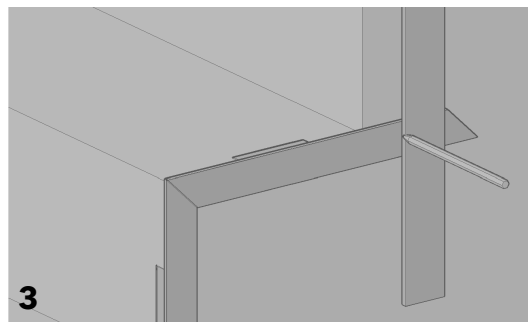

3 Carefully position the welded angle onto the open string of the staircase, making sure they align.

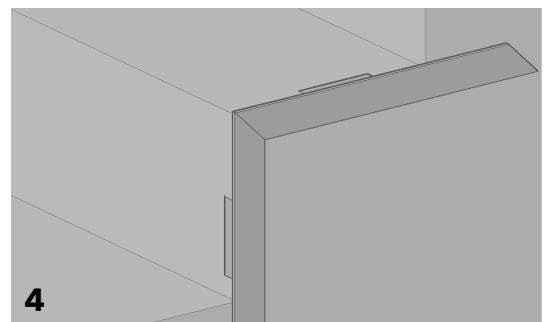

4 Measure and mark the dimensions needed on the welded angle. Cut and de-burr the cut edges of the angle.

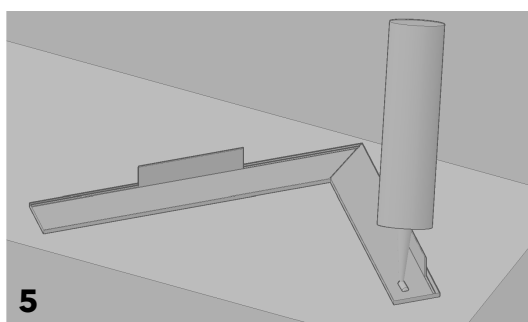

5 Apply a few beads of adhesive along the back edge of the welded angle. Carefully position the welded angle onto the open string of the staircase, making sure the riser of the welded angle will over the cut edge of the stair nosing to be installed.

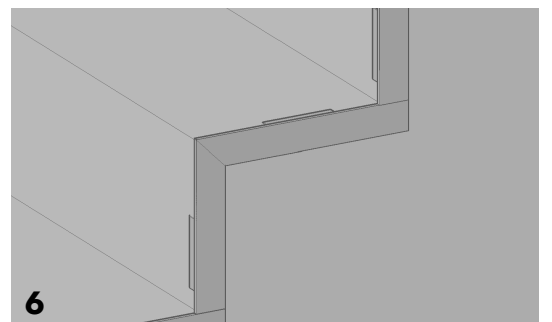

6 Remove any residual adhesive from the riser and tread of the staircase in accordance with the adhesive manufacturers recommendations.

Access to the stairs should only be permitted when the adhesive has had time to fully cure.



CAT *recommends the use of STYCCO FLEX to fix any of its extensive range of stair nosings, stair edgings and stair insert products. STYCCO FLEX is a rapid curing flexible adhesive with excellent gap filling properties that can be used outside as well as inside. *subject to following the instructions given by F. Ball and Co Ltd in their STYCCO FLEX product technical data sheet, safety data sheet and installation guidelines, available in full from: www.f-ball.com

Made with Precision, Finished with Care