

Product Installation Guide

Product Range

Stair nosings with a double channel design to provide for concealed fixings

Product Description

Extruded aluminium stair nosings supplied with one PVC insert factory bonded to the front of the tread area and with a separate, matching PVC concealing insert for on-site retro fitting to provide for hidden fixing in the rear channel.

Profiles supplied cut to customer sizes or in stock lengths for cutting on site, pre-drilled/countersunk for size 8 screws.

PVC infill with double-sided adhesive tape pre-applied into the underside, supplied oversized for trimming on site.

General:

It is recommended that stair nosings are glued and screwed to steps to prevent 'rattle', provide the most secure fixing and ensure product performance.

Ensure that the steps are level and in good repair. Any remedial work should be completed in advance of fixing the stair nosings and where this requires wet treatments, these must be allowed to fully cure before commencing the installation.

Installation:

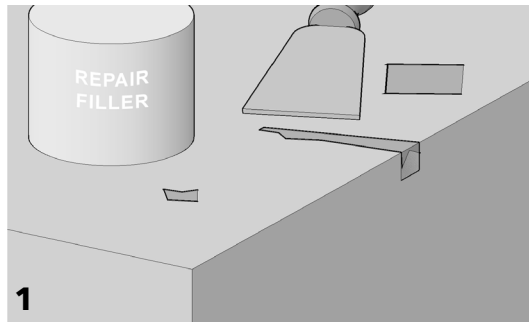

1
Ensure that the steps are level and in good repair. Any remedial work should be completed in advance of fixing the stair nosings and where this requires wet treatments, these must be allowed to fully cure before commencing the installation.

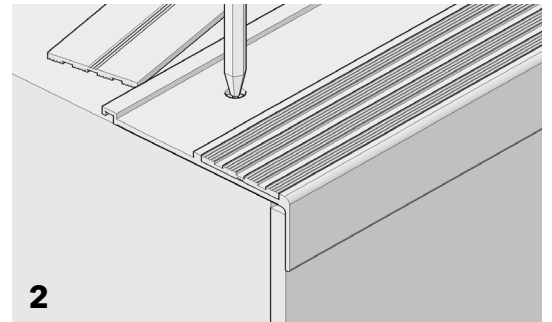

2
Fit the flooring to the riser (where applicable) and place the stair nosings onto the step to mark and drill holes - pilot holes in timber and holes for plastic plugs in solid substrates.

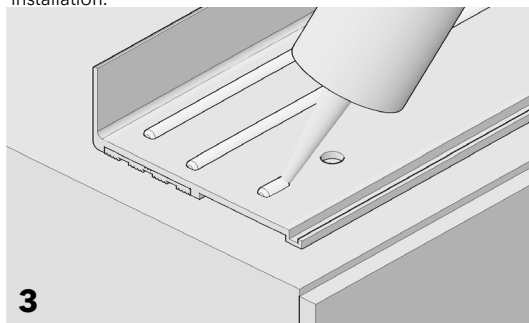

3
Apply three beads of adhesive to the underside of the profile before re-positioning and aligning over the pre-drilled holes.

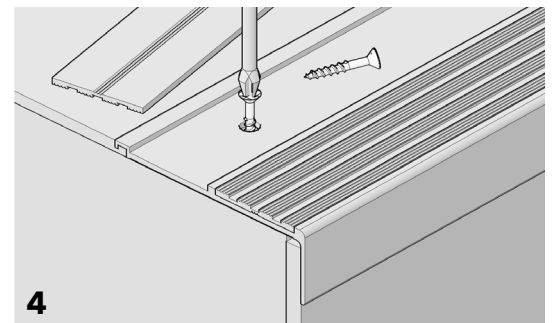

4
Secure with screws ensuring that the screw heads are flush or below the countersink in the profile to ensure that the concealing strip lays flat when installed.

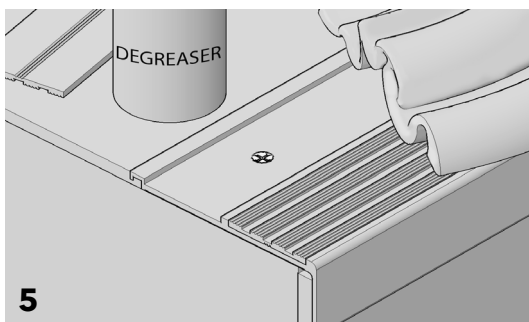

5
Fit the flooring to the step tread before thoroughly degreasing the rear channel of the now fixed profile. Allow all moisture and vapours to fully dissipate before affixing the concealing strip.

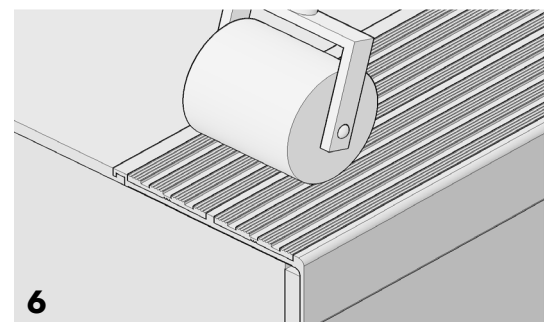

6
Remove the protective film from the self adhesive tape and affix the concealing strip over the screw heads taking care not to stretch it. Finish with a seam roller to ensure complete contact along the entire length of the now joined pieces.

Access to the stairs should only be permitted when the adhesive has had time to fully cure.



CAT *recommends the use of STYCCO FLEX to fix any of its extensive range of stair nosings, stair edgings and stair insert products. STYCCO FLEX is a rapid curing flexible adhesive with excellent gap filling properties that can be used outside as well as inside. *subject to following the instructions given by F. Ball and Co Ltd in their STYCCO FLEX product technical data sheet, safety data sheet and installation guidelines, available in full from: www.f-ball.com

Made with Precision, Finished with Care

CAT Flooring Accessories, Units 24 A,B,C, Park Avenue Estate, Luton, Bedfordshire LU3 3BP, U.K.

T: +44 (0) 1582 561 500

email: sales@catflooringaccessories.com

website: www.catflooringaccessories.com